

# **VEGA 500-TSP**

**Servo Driven  
Three Side Seal Pouch Maker**



**VALUE FOR TRUST**

# VEGA 500-TSP *Servo Driven* Three Side Seal Pouch Maker

Three side seal pouch making made simple. An entry level machine for laminators & convertors wanting to make three side seal pouchs as well as Agarbatti (Incense stick) pouches from PET / BOPP laminates.

## Specifications :

Polymer Processing capability	Laminated PET / BOPP / Unlaminated Co-Ex Films (Nylon based)	
Film Index	Stepper Motor	
<b>Thickness of the Film (microns)</b>	<b>Maximum</b>	<b>Minimum</b>
• Laminates of PET	120	30
• BOPP	60	35
• Unlaminated Co-Ex Films (Nylon-LD)	140	80
<b>Processing Data</b>	<b>Maximum</b>	<b>Minimum</b>
Web Width* (Lay-Flat Sheet width) (mm)	1000	170
Draw Length (mm)	500 #	100
Off-wind Reel Diameter (mm)	600	
Maximum Speed ** (Cycles/Minute)	100	
Electrical Power	AC, 3 Phase, 415 ± 6% Volt, 50 Hz	
Air Consumption at NTP (Liters / Minute)	650	
Foot Print ( L x W x H) (mm)	5500 x 2500 x 1700 (Basic machine with FFD & SRU)	
Machine Weight	~ 1.70 MT	

\* Maximum usable width of the machine may change with attachments  
 \*\* Depending on Type, Size, Material & Thickness

# Higher Draw length on demand or option.

## Attachments :

- Perforation Attachment for making strings
- Pin Hole Punch Assembly (4 Hole)
- Extra Sealers
- Wide Range of Unwinders
- Eprom card for Larger Draw Length Setting
- Bottom Heat Capability
- "V" Notch Punch

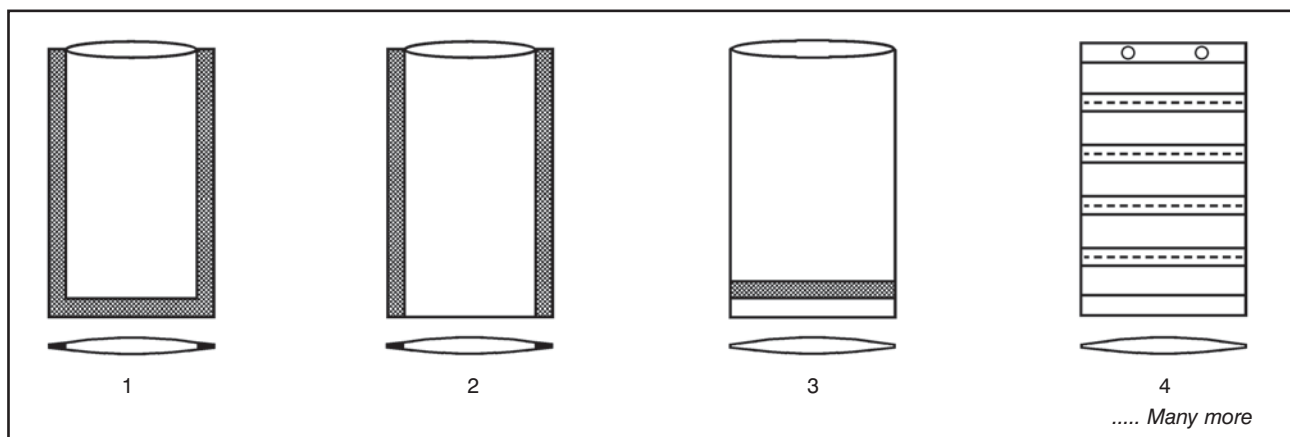

Photographs may show attachments or accessories, which may not be part of the standard scope of supply.  
 The company reserves the right to modify, alter, change or substitute any feature & specifications which are subject to change without notice.

India Office & Works :



Survey No. 423/P, Sarkhej - Bavla Highway, Moraiya,  
 Tal.: Sanand, Dist.:Ahmedabad - 382 213, INDIA.  
 Phone:+91 2717 300700 • E-mail : sales@mamata.com  
 Website: www.mamata.com



USA Office :



2275, Cornell Ave., Montgomery, IL-60538, USA.  
 Phone : +1 630 801 2320 • Fax : +1 630 801 2322  
 E-mail : info@mamatausa.com  
 Website : www.mamatausa.com